

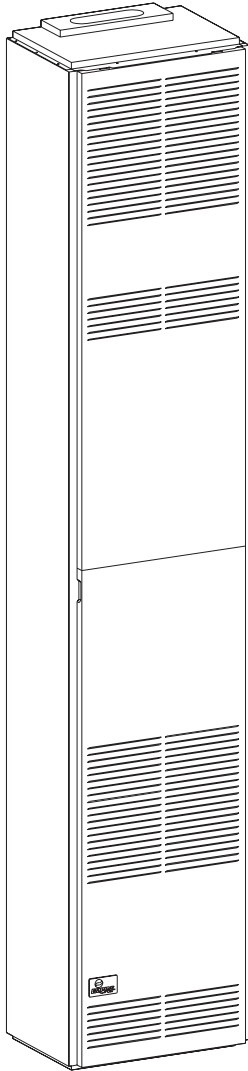

# INSTALLATION INSTRUCTIONS AND OWNER'S MANUAL



## FAN TYPE VENTED WALL FURNACE

MODEL  
FAW-55SPP



**Installer:** Leave this manual with the appliance.  
**Consumer:** Retain this manual for future reference.

**WARNING:** If not installed, operated and maintained in accordance with the manufacturer's instructions, this product could expose you to substances in fuel or from fuel combustion which can cause death or serious illness.

**WARNING:** If the information in these instructions are not followed exactly, a fire or explosion may result causing property damage, personal injury or loss of life.

- Do not store or use gasoline or other flammable vapors and liquids in the vicinity of this or any other appliance.
- **WHAT TO DO IF YOU SMELL GAS**
  - Do not try to light any appliance.
  - Do not touch any electrical switch; do not use any phone in your building.
  - Immediately call your gas supplier from a neighbor's phone. Follow the gas supplier's instructions.
  - If you cannot reach your gas supplier, call the fire department.
- Installation and service must be performed by a qualified installer, service agency or the gas supplier.

## Introduction

Always consult your local Building Department regarding regulations or ordinances which apply to the installation of a vented wall furnace.

## Instructions to Installer

1. Installer must leave instruction manual with owner after installation.
2. Installer must have owner fill out and mail warranty card supplied with furnace.
3. Installer should show owner how to start and operate furnace and thermostat.

### Warning:

**Any change to this furnace or its control can be dangerous. This is a heating appliance and any panel, door or guard removed for servicing an appliance must be replaced prior to operating the appliance.**

## General Information

This series is design certified in accordance with American National Standard/CSA Standard Z21.86 and CSA 2.32 by the Canadian Standards Association, as a Fan Type Vented Wall Furnace and must be installed according to these instructions.

**Any alteration of the original design, installed other than as shown in these instructions or use with a type of gas not shown on the rating plate is the responsibility of the person and company making the change.**

## Important

All correspondence should refer to complete Model No., Serial No. and type of gas.

**Notice:** During initial firing of this unit, its paint will bake out and smoke will occur. To prevent triggering of smoke alarms, ventilate the room in which the unit is installed.

## Installation on Rugs and Tile

If this appliance is installed directly on carpeting, tile or other combustible material other than wood flooring, the appliance shall be installed on a metal or wood panel extending the full width and depth of the appliance.

The base referred to above does not mean the fire-proof base as used on wood stoves. The protection is for rugs that are extremely thick and light colored tile.

## Installation in Residential Garages

Gas utilization equipment in residential garages shall be installed so that all burners and burner ignition devices are located not less than 18" (457mm) above the floor.

Such equipment shall be located, or protected, so it is not subject to physical damage by a moving vehicle.

## Specifications

Model	FAW-55SPP
Input BTU/HR (KW/H)	55,000 (16.1)
Height	82 3/8" (209.2cm)
Width	16" (406mm)
Depth	11 1/2" (292mm)
Gas Inlet	1/2" (13mm) Pipe
Vent Collar	4" 102mm) Type B Oval
CFM	400
Accessories	See Page 12

# THIS IS A HEATING APPLIANCE

DO NOT OPERATE THIS APPLIANCE WITHOUT FRONT PANELS INSTALLED.

- Due to high temperatures, the appliance should be located out of traffic and away from furniture and draperies.
- Children and adults should be alerted to the hazards of high surface temperatures and should stay away to avoid burns or clothing ignition.
- Young children should be carefully supervised when they are in the same room as the appliance.
- Clothing or other flammable material should not be placed on or near the appliance.
- Any safety screen or guard removed for servicing an appliance must be replaced prior to operating the appliance.
- Keep burner and control compartment clean.
- Installation and repair should be done by a QUALIFIED SERVICE PERSON. The appliance should be inspected before use and at least annually by a qualified service person. More frequent cleaning may be required due to excessive lint from carpeting, bedding materials, etc. It is imperative that control compartments, burners and circulating air passageways of the appliance be kept clean.
- Do NOT put anything around the furnace that will obstruct the flow of combustion and ventilation air.
- DO keep the appliance area clear and free from combustible material, gasoline and other flammable vapors and liquids.
- DO examine venting system periodically and replace damaged parts.
- DO make a periodic visual check of pilot and burners. Clean and replace damaged parts.
- CAUTION: Pilot hole cover must be kept tightly closed during operation.
- DO NOT use this heater if any part has been under water. Immediately call a qualified service technician to inspect the heater and to replace any part of the control system and any gas control which has been under water.
- This furnace must not be connected to a chimney flue serving a separate solid-fuel burning appliance.

# SAFETY INFORMATION FOR USERS OF LP-GAS

Propane (LP-Gas) is a flammable gas which can cause fires and explosions. In its natural state, propane is odorless and colorless. You may not know all the following safety precautions which can protect both you and your family from an accident. Read them carefully now, then review them point by

point with the members of your household. Someday, when there may not be a minute to lose, everyone's safety will depend on knowing exactly what to do. If, after reading the following information, you feel you still need more information, please contact your gas supplier.

## LP-GAS WARNING ODOR

**If a gas leak happens, you should be able to smell the gas because of the odorant put in the LP-Gas.**

**That's your signal to go into immediate action!**

- Do not operate electric switches, light matches, use your phone. Do not do anything that could ignite the gas.
- Get everyone out of the building, vehicle, trailer, or area. Do that IMMEDIATELY.
- Close all gas tank or cylinder supply valves.
- LP-Gas is heavier than air and may settle in low areas such as basements. When you have reason to suspect a gas leak, keep out of basements and other low areas. Stay out until firefighters declare them to be safe.
- Use your neighbor's phone and call a trained LP-Gas service person and the fire department. Even though you may not continue to smell gas, do not turn on the gas again. Do not re-enter the building, vehicle, trailer, or area.
- **Finally**, let the service man and firefighters check for escaped gas. Have them air out the area before you return. Properly trained LP-Gas service people should repair the leak, then check and relight the gas appliance for you.

## NO ODOR DETECTED - ODOR FADE

**Some people cannot smell well. Some people cannot smell the odor of the chemical put into the gas. You must find out if you can smell the odorant in propane.** Smoking can decrease your ability to smell. Being around an odor for a time can affect your sensitivity or ability to detect that odor. Sometimes, other odors in the area mask the gas odor. People may not smell the gas odor or their minds are on something else. Thinking about smelling a gas odor can make it easier to smell.

**The odorant in LP-Gas is colorless, and it can fade under some circumstances.** For example, if there is an underground leak, the movement of the gas through soil can filter the odorant.

Odorants in LP-Gas are subject to oxidation. This fading can occur if there is rust inside the storage tank or in iron gas pipes.

The odorant in escaped gas can adsorb or absorb onto or into walls, masonry and other materials and fabrics in a room. That will take some of the odorant out of the gas, reducing its odor intensity.

LP-Gas may stratify in a closed area, and the odor intensity could vary at different levels. Since it is heavier than air, there may be more odor at lower levels. Always be sensitive to the slightest gas odor. If you detect any odor, treat it as a serious leak. Immediately go into action as instructed earlier.

## SOME POINTS TO REMEMBER

- **Learn to recognize the odor of LP-gas.** Your local LP-Gas Dealer can give you a "Scratch and Sniff" pamphlet. Use it to find out what the propane odor smells like. If you suspect that your LP-Gas has a weak or abnormal odor, call your LP-Gas Dealer.
- If you are not qualified, do not light pilot lights, perform service, or make adjustments to appliances on the LP-Gas system. If you are qualified, consciously think about the odor of LP-Gas prior to and while lighting pilot lights or performing service or making adjustments.
- Sometimes a basement or a closed-up house has a musty smell that can cover up the LP-Gas odor. Do not try to light pilot lights, perform service, or make adjustments in an area where the conditions are such that you may not detect the odor if there has been a leak of LP-Gas.
- Odor fade, due to oxidation by rust or adsorption on walls of new cylinders and tanks, is possible. Therefore, people should be particularly alert and careful when new tanks or cylinders are placed in service. Odor fade can occur in new tanks, or reinstalled old tanks, if they are filled and allowed to set too long before refilling. Cylinders and tanks which have been out of service for a time may develop internal rust which will cause odor fade. If such conditions are suspected to exist, a periodic sniff test of the gas is advisable. **If you have any question about the gas odor, call your LP-Gas Dealer. Aperiodic sniff test of the LP-Gas is a good safety measure under any condition.**
- If, at any time, you do not smell the LP-Gas odorant and you think you should, assume you have a leak. Then take the same immediate action recommended above for the occasion when you do detect the odorized LP-Gas.
- If you experience a complete "gas out" (the container is under no vapor pressure), turn the tank valve off immediately. If the container valve is left on, the container may draw in some air through openings such as pilot light orifices. If this occurs, some new internal rusting could occur. If the valve is left open, then treat the container as a new tank. Always be sure your container is under vapor pressure by turning it off at the container before it goes completely empty or having it refilled before it is completely empty.

## Ventilation and Combustion Air

Wall furnaces shall be installed in a location in which the facilities for ventilation permit satisfactory combustion of gas and proper venting under normal conditions. In buildings of conventional frame, brick, or stone construction without tight storm windows and doors, infiltration is normally adequate to provide air for combustion and draft hood dilution.

Where appliances are installed in confined and unconfined spaces within a building, the building being of unusually tight construction, air for combustion and ventilation must be obtained directly from outdoors or from such spaces that freely communicate with the outdoors. Under these conditions, the confined and unconfined spaces shall be provided with two permanent openings, one near the top of the enclosure and one near the bottom; each opening shall have a free area of not less than one square inch (6.45cm<sup>2</sup>) per 2,000 BTU hr. (.6KW/H) of total input.

## Qualified Installing Agency

Installation and replacement of gas piping, gas utilization equipment or accessories and repair and servicing of equipment shall be performed only by a qualified agency. The term "qualified agency" means any individual, firm, corporation or company which either in person or through a representative is engaged in and is responsible for (a) the installation or replacement of gas piping or (b) the connection, installation, repair or servicing of equipment, who is experienced in such work, familiar with all precautions required and has complied with all the requirements of the authority having jurisdiction.

**State of Massachusetts:** The installation must be made by a licensed plumber or gas fitter in the Commonwealth of Massachusetts.

The installation must conform with local codes or, in the absence of local codes, with the National Fuel Gas Code, ANSI Z223.1/NFPA 54\* Natural Gas and Propane Installation Code, CSA B149.1.

*\*Available from the American National Standards Institute, Inc., 11 West 42nd St., New York, N.Y. 10036.*

## Clearances

1. In selecting a location for installation, it is necessary to provide adequate accessibility clearances for servicing and proper installation.
2. The FAW-55 can be attached to the wall or recessed into the wall up to 4 inches (102mm) in depth.
3. The wall in which the furnace is recessed has (0) zero (0mm) clearance to the furnace sides and top.
4. When using side discharge registers, SOR-1 or SOK-1, the furnace cannot be recessed into the wall.
5. Clearance to sidewall or combustible material is 4 inches (102mm).
6. Ceiling clearance is 7 1/2 inches (191mm)
7. Floor and rear wall clearance is (0) zero inches (0mm).
8. Clearance of 18 inches (457mm) is required to adjacent wall or combustible material when flushed mounted SOR-1, side outlet register is used.

## Before Installing Consider The Following Venting

1. A chimney for residential-type or low-heat gas utilization equipment shall extend at least 3 feet (914mm) above the highest point where it passes through a roof of a building and at least 2 feet (610mm) higher than any portion of building within a horizontal distance of 10 feet (3m).
2. This furnace must not be connected to a chimney flue serving a separate solid-fuel burning appliance.
3. Uninsulated Single-Wall Metal Pipe shall not be used outdoors in cold climates for venting gas utilization equipment.
4. Attention! This Fan Type Vented Wall Furnace is equipped with a vent safety switch. In the event of spillage of flue products due to improper venting the vent safety switch will open, which results in

the main burners to "shut off."

Refer to Figure 1 and Page 12 for additional information regarding U.L. Listed gas vent equipment.

## Installing Optional Side Outlets

Side outlet register, SOR-1 may be installed on one or both sides of the furnace at the required clearances of 18 inches (457mm) to adjacent wall or combustible material as shown in Figure 2.

1. Locate and cut the 5 1/2" (140mm) square opening in the cabinet side using the template from the kit, exposing the inner liner knock-out.
2. Remove the knock-out.
3. Place the register on the 5 1/2" (140mm) opening with the louvers set for the desired direction and mark the mounting holes using the register as a template.
4. Drill two (2) 1/8" (3mm) diameter holes in cabinet side and fasten the register in place with two (2) #10 x 1" (25mm) screws provided.

Side outlet kit, 10" (254mm) boot assembly with register, SOK-1 for warm air discharge into an adjoining room may be installed on either side of the furnace at the required clearance of 4 inches (102mm) to adjacent wall as shown in Figure 3A.

1. Locate and cut the 5 1/2" (140mm) square opening in the cabinet side using the template from the kit, exposing the inner liner knock-out.
2. Remove the knock-out.
3. Using the inner and outer boots as hole templates, mark and drill (8) 1/8" (3mm) diameter holes in the inner liner and cabinet side.
4. Using Figure 3A locate and cut a 6 3/4" (171mm) square opening through walls.
5. Attach furnace to wall (see **Attaching Furnace to Wall**).
6. With furnace in place, after checking alignment of side outlet opening in wall and furnace, place the 9 3/8" x 9 3/8" (238mm x 238mm) side outlet wall plate over outer boot, pass the outer boot through the wall and attach side outlet wall plate to furnace side of wall with (2) #10 x 1" (25mm) screws provided.
7. Fasten outer boot to the cabinet side with (4) #8 x 1/4" (6mm) screws provided.
8. Position and attach inner boot to inner liner with (4) #8 x 1/4" (6mm) screws provided.
9. Locate the register with its louvers positioned for the desired air discharge direction and mark the mounting holes using the register as a template.
10. Drill (2) 1/8" (3mm) diameter holes in the wall and fasten the register in place with (2) #10 x 1" (25mm) screws provided.

## Installing Optional Rear Outlet

Rear outlet kit, 10" (254mm) boot assembly with register, ROK-1 for warm air discharge into an adjoining room.

**Attention:** Before furnace is attached to the wall, the wall opening for the rear outlet must be cut, in addition to removal of the outer and inner casing knockouts on furnace.

1. The wall opening measurements for the rear outlet are the following.
  - A. From floor to bottom of wall opening is 14 3/4" (375mm).
  - B. From the bottom of wall opening to top of wall opening is 8 1/2" (216mm).
  - C. Wall opening width is 12 1/8" (308mm).
2. Remove outer casing knockout from outer casing back.
3. Remove inner casing knockout from inner casing.
4. Attach furnace to wall (see **Attaching Furnace to Wall**).
5. Align clearance holes on 8" x 12" (203mm x 305mm) boot with screw holes on outer casing back and mark boot to be flush with wall surface. Remove boot and cut to proper length.
6. Attach 8" x 12" (203mm x 305mm) boot to outer casing back with (6) #10 x 1/2" (13mm) screws provided.
7. Align clearance holes on 6" x 10" (152mm x 254mm) duct with screw holes on inner casing and mark duct to be 2 1/4" (57mm) shorter than

8" x 12" (203mm x 305mm) boot. Remove duct and cut to proper length.

8. Attach 6" x 10" (152mm x 254mm) duct to inner casing with (6) #10 x 1/2" (13mm) screws provided.
9. Insert rear register into 8" x 12" (203mm x 305mm) boot. Attach rear register to wall with (2) #10 x 1" (25mm) screws provided.

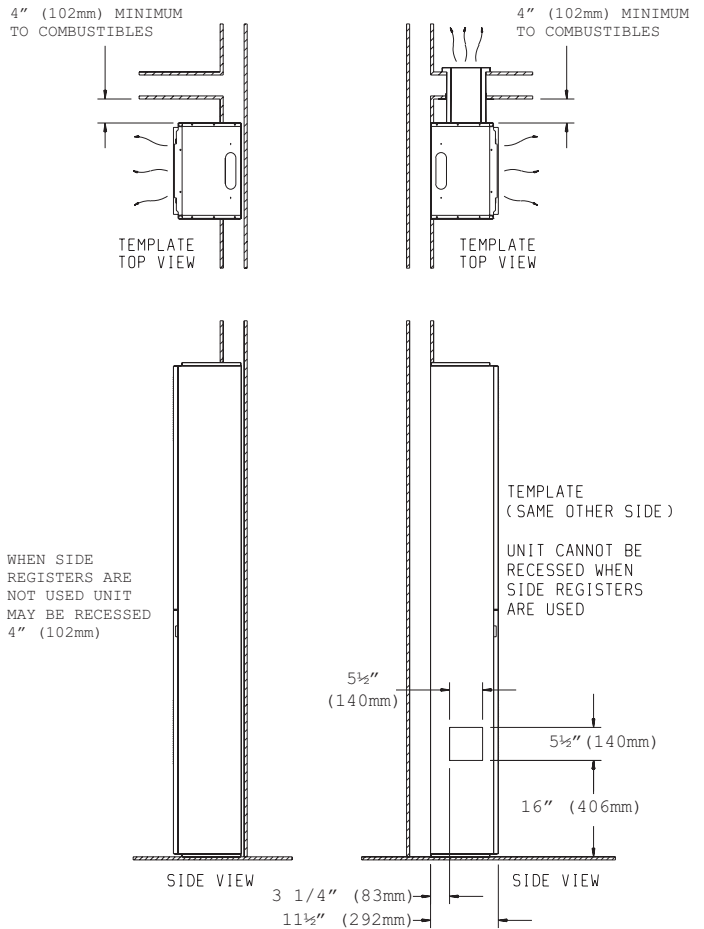
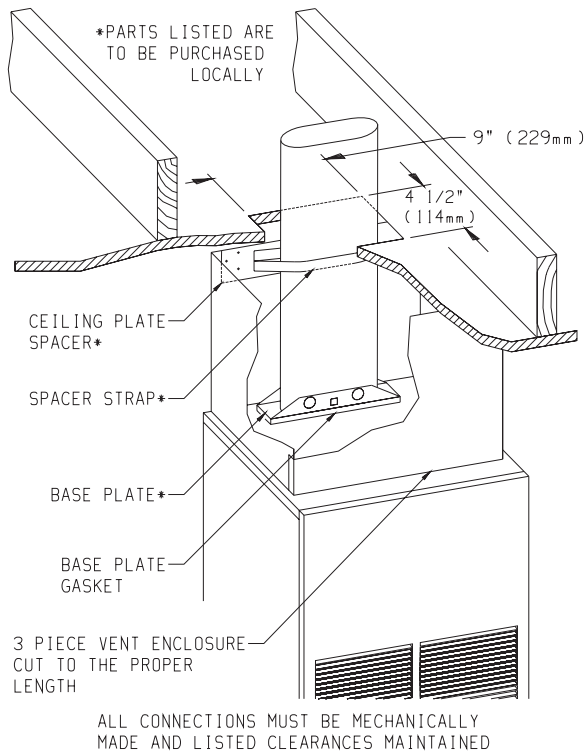

### Locating Furnace On Wall

The furnace is to be located on a wall. The furnace is 16 inches (406mm) in width and normal 16" (406mm) on center studs will not allow the furnace to be recessed into the wall unless a stud is repositioned.

A template is provided in furnace carton for locating gas line connection. Also, refer to Figure 2 for positioning the furnace on wall and for locating gas line connection.

### Locating Gas Supply

The gas line can enter the furnace either through the floor or wall. The gas line opening should be made at this time. Location of the opening will be determined by the position of floor joists and the valve and union used for servicing.

### Location Electric Supply

A 7/8" (22mm) diameter knockout is provided at the bottom of the left and right side panels. A three-prong (grounding) plug assembly is located within the control compartment (bottom) of the furnace. Please remove 7/8" (22mm) knockout from appropriate side panel when routing plug assembly to an electrical outlet.

### Installation of Three-prong (Grounding) Plug Assembly

1. Disconnect nylon cap on 3' (914mm) plug assembly from nylon plug on wiring harness. Remove 3' (914mm) plug assembly from control compartment (bottom) of the furnace.
2. Remove 7/8" (22mm) knockout from appropriate side panel.
3. Insert nylon cap on 3' (914mm) plug assembly into the 7/8" (22mm) hole in the side panel.
4. Connect nylon cap on 3' (914mm) plug assembly to nylon plug on the wiring harness.
5. Place 7/8" (22mm) strain relief bushing around the cord of the 3'

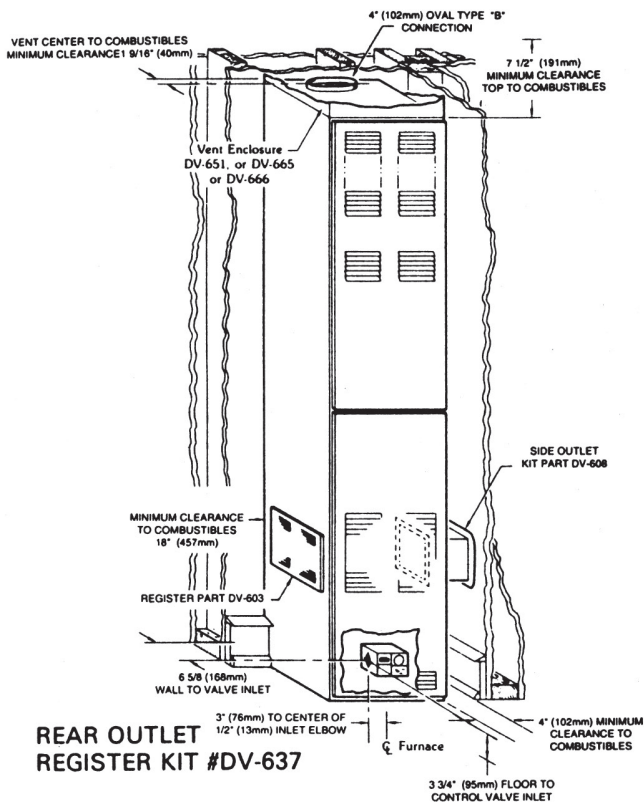

(914mm) plug assembly. Insert 7/8" (22mm) strain relief bushing into the 7/8" (22mm) hole in the side panel.

**Attention!** The 7/8" (22mm) strain relief bushing is located within the same yellow envelope as the Installation Instructions and Owner's Manual.

### Attaching Furnace to Wall

When attaching furnace to the wall remove that portion of baseboard and molding on the wall which is behind the furnace. Attach furnace to wall, at the outer casing top, with (2) toggle bolts provided and to floor, at the outer casing bottom, with (2) #10 x 1 1/2" (38mm) screws provided.

**Attention!** The screw holes on the outer casing bottom are off-set above the floor approximately 3/8" (9.5mm). Do not over-tighten screws and distort the off-set on the outer casing bottom. Distortion of the outer casing bottom will not allow the lower front panel to be attached to the furnace.

### Gas Supply

Check all local codes for requirements, especially for the size and type of gas supply line required. On Natural gas lines less than 15' (4.5m) long, use 1/2" (13mm) pipe; on longer runs, use 3/4" (19mm) iron pipe or equal. On LP gas lines please consult LP gas supplier.

### Installing a New Main Gas Cock

Each appliance should have its own manual gas cock.

A manual main gas cock should be located in the vicinity of the unit. Where none exists, or where its size or location is not adequate, contact your local authorized installer for installation or relocation.

Compounds used on threaded joints of gas piping shall be resistant to the action of liquefied petroleum gases. The gas lines must be checked for leaks by the installer. This should be done with a soap solution watching for bubbles on all exposed connections, and if unexposed, a pressure test should be made.

**Never use an exposed flame to check for leaks. Appliance must be disconnected from piping at inlet of control valve and pipe capped or plugged for pressure test. Never pressure test with appliance connected; control valve will sustain damage!**

A gas valve and ground joint union should be installed in the gas line upstream of the gas control to aid in servicing. It is required by the National Fuel Gas Code that a drip line be installed near the gas inlet. This should consist of a vertical length of pipe tee connected into the gas line that is capped on the bottom in which condensation and foreign particles may collect.

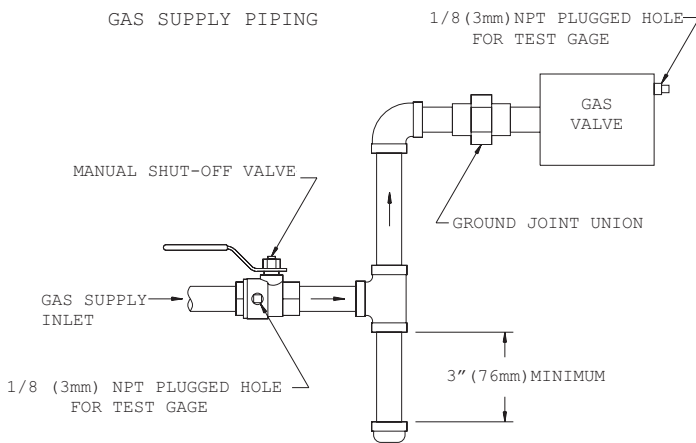

Figure 4

### Method of Installing a Tee Fitting Sediment Trap

The use of the following gas connectors is recommended:

- ANS Z21.24 Appliance Connectors of Corrugate Metal Tubing and Fittings

- ANS Z21.45 Assembled Flexible Appliance Connectors of Other Than All-Metal Constructions

The above connectors may be used if acceptable by the authority having jurisdiction.

### Pressure Testing of the Gas Supply System

1. To check the inlet pressure to the gas valve, a 1/8" (3mm) N.P.T. plugged tapping, accessible for test gauge connection, must be placed immediately upstream of the gas supply connection to the appliance.
2. The appliance and its individual shutoff valve must be disconnected from the gas supply piping system during any pressure testing of that system at test pressures in excess of 1/2 psig (3.5 kPa).
3. The appliance must be isolated from the gas supply piping system by closing its individual manual shutoff valve during any pressure testing of the gas supply piping system at test pressures equal to or less than 1/2 psig (3.5 kPa).

**Attention!** If one of the above procedures results in pressures in excess of 1/2 psig (14" w.c.) (3.5 kPa) on the appliance gas valve, it will result in a hazardous condition.

### Checking Manifold Pressure

Both Propane and Natural gas valves have a built-in pressure regulator in the gas valve. Natural gas models will have a manifold pressure of approximately 4.0" w.c. (.996kPa) at the valve outlet with the inlet pressure to the valve from a minimum of 5.0" w.c. (1.24kPa). Propane gas models will have a manifold pressure approximately 10.0" w.c. (2.49kPa) at the valve outlet with the inlet pressure to the valve from a minimum of 11.0" w.c. (2.739kPa) for the purpose of input adjustment to a maximum of 13.0" w.c. (3.237kPa).

A 1/8" (3mm) N.P.T. plugged tapping, accessible for test gauge connection, is located on the outlet side of the gas control.

The built-in regulator comes on at approximately 1/4th pressure and full on in 10 seconds.

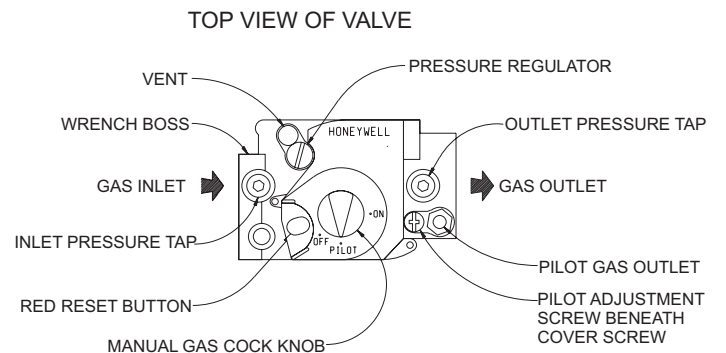

Figure 5

### High Altitudes

For altitudes/elevations above 2,000 feet (610m), input ratings should be reduced at the rate of 4 percent for each 1,000 feet (305m) above sea level. Canadian High Altitudes for locations having an elevation above mean sea level between 2,000 feet (610m) and 4,500 feet (1370m), the manifold pressure is to be decreased from 4.0" w.c. (.996kPa) to 3.2" (.797kPa) w.c. for Natural Gas and from 10.0" w.c. (2.49kPa) to 8.0" w.c. (1.992kPa) for Propane Gas.

### Piezo Pilot Ignitor Instructions

Depressing the red button completely causes a spark to occur at the pilot. This is a substitute for a match which requires opening the pilot hole cover.

To light the pilot, it is important that the electrode be 1/8" (3mm) from the thermocouple. The spark must occur at the point the burner flame hits the thermocouple. The end of the electrode will be red hot with the pilot on.

On a new installation with air in the gas line, it is suggested that a match be used. The match will light the pilot faster than the piezo under this condition.

### Proper Pilot Flame

The correct pilot flame (Figure 6) will be blue, extending past the thermocouple. The flame will surround the thermocouple just below the tip.

Natural gas pilots require adjusting when the inlet gas pressure is above 5" w.c. (1.245kPa). Remove the pilot cover screw on the control valve (Figure 5), and turn the adjustment screw clockwise to reduce flame. Replace pilot cover screw to eliminate gas leakage.

LP gas (propane) will not require adjustment.

After use, cleaning may be required for the proper flame.

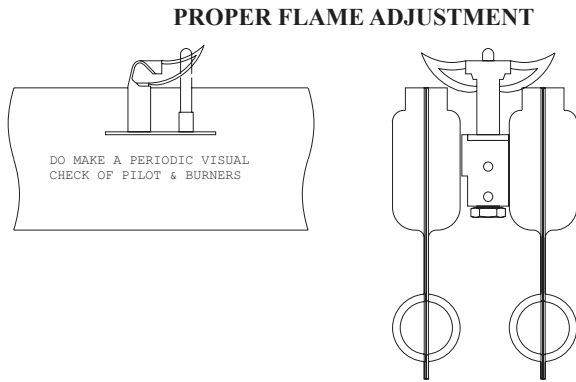

Figure 6

### Proper Main Burner Flame

The correct flame will be a short blue inner flame with a much larger light blue outer flame. The main burner (Figure 7) shows the approximate height of each part of the flame for each gas. The burner does not have a primary air adjustment. The flame will be correct if the factory-set pressure and orifice opening are used. After the furnace has been operating, the burner ports may be blocked by foreign matter carried in by combustion air. Therefore, cleaning of the burner may be needed for proper flame.

To clean burner port disconnect the gas supply to the valve, and remove the eight screws fastening the burner door. After removing the burner door from the combustion chamber, remove rear burner, pilot burner and front burner. With front and rear burners removed from furnace, force water into the ribbon ports and dry with air pressure.

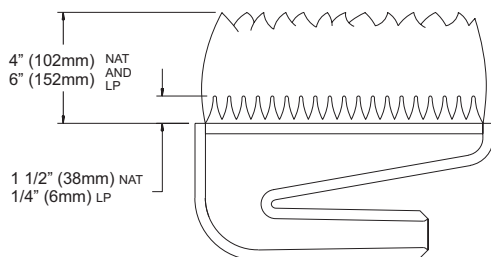

Figure 7

### Replacing Fan and Oiling the Motor

The fan motor should be cleaned and oiled once each heating season. To reach the motor, withdraw the metal shroud surrounding the fan blade by removing the screws on each side. Oil holes are located on the top at each end of the motor. Use a few drops of #10 motor oil. To clean the motor, blow air through its ventilation openings with a vacuum cleaner or low pressure air source.

If fan motor is replaced, the silicone rubber gaskets, see Page 10, Index No. 5, Part 712059, should also be replaced. The gaskets must be stretched to fit the motor bolts into the gasket holes and then the motor and gaskets installed on the motor mounting bars.

### Wiring

The appliance, when installed, must be electrically grounded in accordance with local codes or, in the absence of local codes with the *National Electrical Code, ANSI/NFPA70* or *Canadian Electrical Code CSA C22.1*, if an external electrical source is utilized. **This appliance is equipped with a three-prong (grounding) plug for your protection against shock hazard and should be plugged directly into a properly grounded three-prong receptacle. Do not cut or remove the grounding prong from this plug.** For an ungrounded receptacle, an adapter, which has two prongs and a wire for grounding, can be purchased, plugged into the ungrounded receptacle and its wire connected to the receptacle mounting screw. With this wire completing the ground, the appliance cord plug can be plugged into the adapter and be electrically grounded. A 7/8" (22mm) hole is provided in the junction box for use with a conduit connector if local codes require this type of protection.

### Thermostat Installation

The thermostat should be installed in the same room as the furnace 4' (1.2m) to 5' (1.5m) above the floor and away from another heat source (cooking stove, hot water heater, etc.) including walls and doorways with a heat source in an adjoining room. **Do Not Install Thermostat on Outside Wall.**

### Insulated Vent Enclosure

Vented wall furnaces installed in buildings with flat roofs can have poor venting. The cold vent pipe will have a delay in proper venting and cause the wall furnace to shut "OFF" by the vent safety switch. To prevent delayed venting as well as condensation of flue products an insulated vent enclosure is recommended.

Use type B vent pipe and maintain at least one inch (25mm) clearance to combustibles.

Use metal thimble to protect vent pipe as it passes through combustibles.

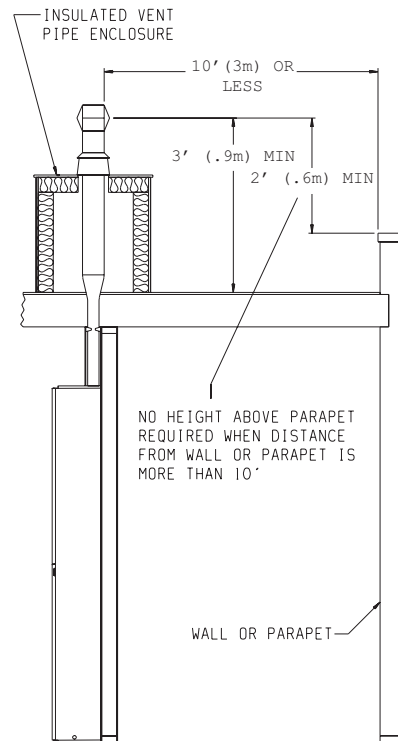

NOTE: MAINTAIN CLEARANCE TO COMBUSTIBLE MATERIALS

Figure 8

## Vent Safety Shutoff System

This appliance must be properly connected to a venting system. This appliance is equipped with a vent safety shutoff system.

**Warning: Operation of this wall furnace when not connected to a properly installed and maintained venting system or tampering with the vent safety shutoff system can result in carbon monoxide (CO) poisoning and possible death.**

This furnace is equipped with a manual reset vent safety switch. The manual reset vent safety switch will cause gas flow to the main burners to “shut off” due to improper venting or a blocked flue.

To reset the manual reset vent safety switch:

1. Remove upper front panel.
2. Depress red manual reset button. The manual reset vent safety switch is located on the draft diverter.
3. Replace upper front panel.

If the manual reset vent safety switch continues to “shut off” the gas flow to the main burners a qualified service person must be contacted to inspect for improper venting, blockage in the vent pipe or the manual reset vent safety switch for being defective.

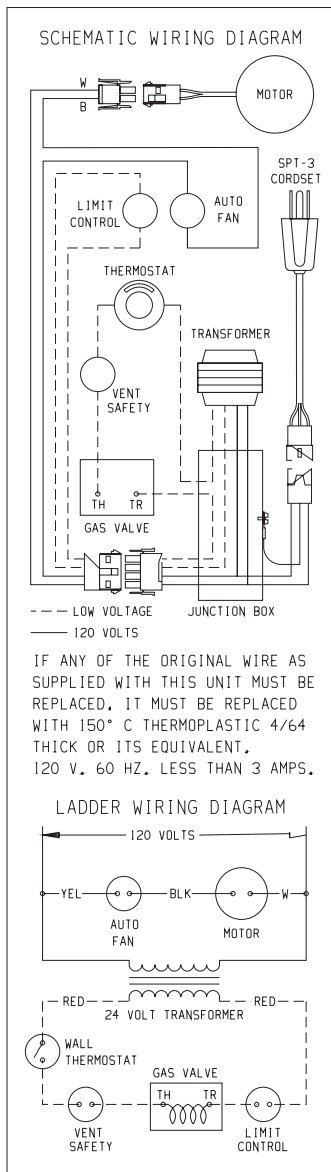

Figure 9

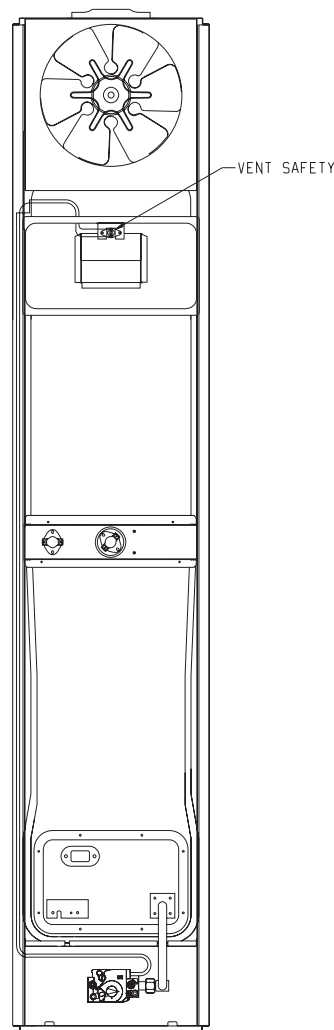

Figure 10

## SERVICE AND MAINTENANCE SUGGESTIONS

### CALL SERVICEMAN

**GENERAL:** All furnaces have been fire-tested to check for proper operation. This includes, main burner flame, pilot flame, fan operation, fan control, limit control and automatic valve operation. If the furnace fails to function on initial installation, it is advisable to re-check the following:

1. 115 volts to the junction box.
2. Inlet gas pressure.
3. The 24 volt system
4. Type of gas being used and that shown on the rating label.

The Service Department at Empire Comfort Systems, Inc. may be contacted to assist in servicing furnace.

**Servicing the Pilot and Main Burners, Pilot Orifice, Thermocouple, and Main Burner Orifices:** Disconnect the gas supply at the inlet to the control valve. Then remove the burner door to which the above components are attached.

**Servicing The Fan Motor:** The upper front panel the shroud surrounding the fan blade and fan blade must be removed. See “oiling the Motor” paragraph on page 7.

**Spark Igniter Does Not Light Pilot:** With air in the gas line, such as when the furnace is first installed or was off all summer, the pilot flame may be too lean to ignite on the first few trials. Turn the control valve knob to pilot position and depress the red reset button. Holding the button down continually to bleed the line;

1. Use lighter rod to light pilot with a match.
2. Use the piezo ignitor at 30 second intervals until it lights.

**If Electrode Does Not Produce Spark**

1. Check wire connections.
2. Check gap for pilot burner to the electrode tip. Should be between 1/8” (3mm) and 3/16” (5mm). Electrode wire and tip must be more than 1/4” (6mm) away from all other metal components.

**If Pilot Does Not Light By Any Means:**

1. Check valve knob for being in the “Pilot” position.
2. Check pilot adjustment for being full open (counterclockwise to open).
3. If gas is available in the supply tubing, the pilot orifice and/or pilot burner is probably restricted by a spider web. Clean pilot assembly and relight.

**If Pilot Does Not Remain On After Releasing Knob:**

1. Follow instructions and hold button down longer and harder.
2. Determine if pilot flame extends past thermocouple; if not, adjust input or clean pilot burner.
3. Replace thermocouple if millivolts read less than 15 millivolts.

**Main Gas Valve Does Not Open When Thermostat is Turned To On:**

1. Check for 24 volts to valve by removing one wire and touch to the **SAME TERMINAL** it was on. Terminal should have a light spark. **DO NOT SHORT ACROSS TERMINALS, AS IT WILL BURN OUT THE WALL THERMOSTAT.**
2. Thermostat wires at the wall may be shorted, so check for a faulty thermostat.
3. To check for line voltage to furnace, remove lower front panel and switch compartment cover and short across two-terminal fan control to allow fan to operate (Figure 9).

**CAUTION:** Label all wires prior to disconnection when servicing controls. Wiring errors can cause improper and dangerous operation. Verify proper operation after servicing.

## FOR YOUR SAFETY READ BEFORE LIGHTING

**WARNING: If you do not follow these instructions exactly, a fire or explosion may result causing property damage, personal injury or loss of life.**

**A. This appliance has a pilot which must be lighted by hand. When lighting the pilot, follow these instructions exactly.**

**B. BEFORE LIGHTING** smell all around the appliance area for gas. Be sure to smell next to the floor because some gas is heavier than air and will settle on the floor.

### WHAT TO DO IF YOU SMELL GAS

- Do not try to light any appliance.
- Do not touch any electrical switch; do not use any phone in your building.
- Immediately call your gas supplier from a neighbor's phone, Follow the gas supplier's instructions.

•If you cannot reach your gas supplier, call the fire department.

**C. Use only your hand to push in or turn the gas control knob. Never use tools. If the knob will not push in or turn by hand, don't try to repair it; call a qualified service technician. Force or attempted repair may result in a fire or explosion.**

**D. Do not use this appliance if any part has been under water. Immediately call a qualified service technician to inspect the appliance and to replace any part of the control system and any gas control which has been under water.**

## LIGHTING INSTRUCTIONS

1. STOP! Read safety information above.
2. Set the thermostat to lowest setting.
3. Turn off all electric power to the appliance.
4. Remove control access panel (lower front panel).
5. Turn gas control knob clockwise  to "OFF."

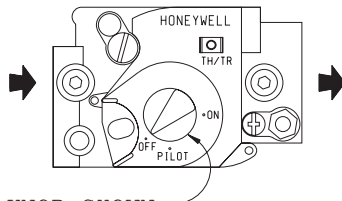

GAS CONTROL KNOB SHOWN IN "OFF" POSITION.

6. Wait ten (10) minutes to clear out any gas. Then smell for gas, including near the floor. If you smell gas, STOP! Follow "B" in the safety information above. If you don't smell gas, go to the next step.
7. Remove the pilot access cover located on the combustion chamber.
8. Find pilot - follow metal tube from gas control. The pilot is located between the two burner tubes behind the pilot access cover.

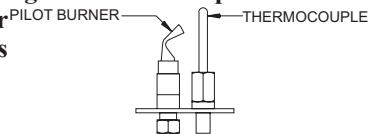

9. Turn gas control knob counterclockwise  to "Pilot."
10. Push and hold red reset button down completely and repeatedly push the ignitor button until the pilot burner is lit. Pilot may also be lit with a match. Continue to hold the red reset button down for about one (1) minute after the pilot is lit. Release button and it will pop back up. Pilot should remain lit. If it goes out, repeat step 5 through 10.

- If button does not pop up when released, stop and immediately call a qualified service technician or gas supplier.
- If the pilot will not stay lit after several tries, turn the gas control knob to "OFF" and call your service technician or gas supplier.

11. Replace pilot access cover.
12. Turn gas control knob counterclockwise  to "ON."
13. Replace control access panel (lower front panel).
14. Turn on all electric power to the appliance.
15. Set thermostat to desired setting.

## TO TURN OFF GAS TO APPLIANCE

1. Set the thermostat to lowest setting.
2. Turn off all electric power to appliance if service is to be performed.
3. Remove control access panel (lower front panel).

4. Push in gas control knob slightly and turn clockwise  to "OFF." Do not force.
5. Replace control access panel (lower front panel).

Please Note: When ordering parts, it is very important that part number and description of part coincide.

Index No.	Part No.	Description	Index No.	Part No.	Description
1	WFA-115	BASEPLATE GASKET	29	712045	MANIFOLD GASKET
2	11763	OUTER CASING TOP	30	DV-064	COVER PLATE FOR OBSERVATION HOLE
3	632024	MOTOR MOUNT (FOUR REQUIRED)	31	DV-622	BURNER DOOR NATURAL GAS
4	11764	MOTOR MOUNTING BAR (TWO REQUIRED)	31	DV-973	BURNER DOOR LP GAS
5	712059	GASKET (TWO REQUIRED)	32	DV-775	SEAL BRACKET
6	R-619	MOTOR	33	712059	GASKET TUBING SEAL
7	11787	FAN BLADE	34	722040	MANIFOLD UNION
8	DV-635-B	COMBUSTION CHAMBER	35	R-5655	GAS VALVE VR8200C LP GAS
9	11766	FAN HOUSING	35	R-2148	GAS VALVE VR8200C NATURAL GAS
10	11759	SIDE PANEL	36	UH-810	TRANSFORMER MOUNTING BRACKET
11	DV-627	UPPER FRONT PANEL	37	R-1995	TRANSFORMER
12	R-1619	BUSHING	38	UH-451	JUNCTION BOX COVER
13	DV-823	DIVERTER ASSEMBLY	39	11761	OUTER CASING BOTTOM (USA)
14	R-1749	VENT SAFETY SWITCH	39	15670	OUTER CASING BOTTOM (CANADA)
15	R-1587	VENT SAFETY WIRE ASSEMBLY	40	8720148	BUSHING
16	8720130	BUSHING	41	R-2708	PIEZO IGNITOR
17	11765	SWITCH COMPARTMENT ASSEMBLY	42	872053	CORD SET
18	DV-832	SWITCH COMPARTMENT COVER	43	872087	BUSHING
19	912073	LIMIT CONTROL	44	DV-671	MANIFOLD SUPPORT
20	R-1941	FAN CONTROL	45	DV-765	GASKET FOR CHAMBER AIR INLET (TOP & BOTTOM) (2 REQUIRED)
21	DV-826	REAR BURNER	46	DV-764	GASKET FOR CHAMBER AIR INLET (SIDES) (TWO REQUIRED)
22	672046	THERMOCOUPLE	47	8720140	BUSHING
23	762214	PILOT WITH ORIFICE LP GAS	48	DV-684	INNER LINING ASSEMBLY
23	762111	PILOT WITH ORIFICE NATURAL GAS	49	DV-629	CASING BACK
24	DV-808	PILOT TUBING	50	11759	SIDE PANEL
25	DV-562	LOWER FRONT PANEL (USA)	NOT SHOWN	R-9832	WIRE ASSEMBLY UPPER
25	15667	LOWER FRONT PANEL (CANADA)	NOT SHOWN	R-9833	WIRE ASSEMBLY LOWER
26	DV-824	FRONT BURNER	NOT SHOWN	R-6389	24 VOLT WALL THERMOSTAT
27	P-88-42	MAIN BURNER ORIFICE NATURAL GAS (TWO REQUIRED)	NOT SHOWN	862060	LIGHTER ROD
27	742223	MAIN BURNER ORIFICE LP GAS (TWO REQUIRED)	NOT SHOWN	742265	PILOT ORIFICE LP
28	DV-687	MANIFOLD AND PLATE ASSEMBLY	NOT SHOWN	R3469	PILOT ORIFICE NATURAL

USE ONLY MANUFACTURER'S REPLACEMENT PARTS. USE OF ANY OTHER PARTS COULD CAUSE INJURY OR DEATH.

### How To Order Repair Parts...

Parts can be ordered only through your **service person or dealer**. For best results, the service **person or dealer** should order parts through the distributor. Parts can be shipped directly to the **service person/dealer**.

All parts listed in the Parts List have a Part Number. When ordering parts, first obtain the Model Number from the name plate on your equipment. Then determine the Part Number (not the Index Number) and the Description of each part from the following appropriate illustration and list. Be sure to give all this information...

Furnace Model Number \_\_\_\_\_ Part Description \_\_\_\_\_

Furnace Serial Number \_\_\_\_\_ Part Number \_\_\_\_\_

Type of Gas (Propane or Natural) \_\_\_\_\_

Do not order bolts, screws, washers or nuts. They are standard hardware items and can be purchased at any local hardware store.

Shipments contingent upon strikes, fires and all causes beyond our control.

Empire Comfort Systems, Inc. Nine Eighteen Freeburg Ave. Belleville, Illinois 62222-0529

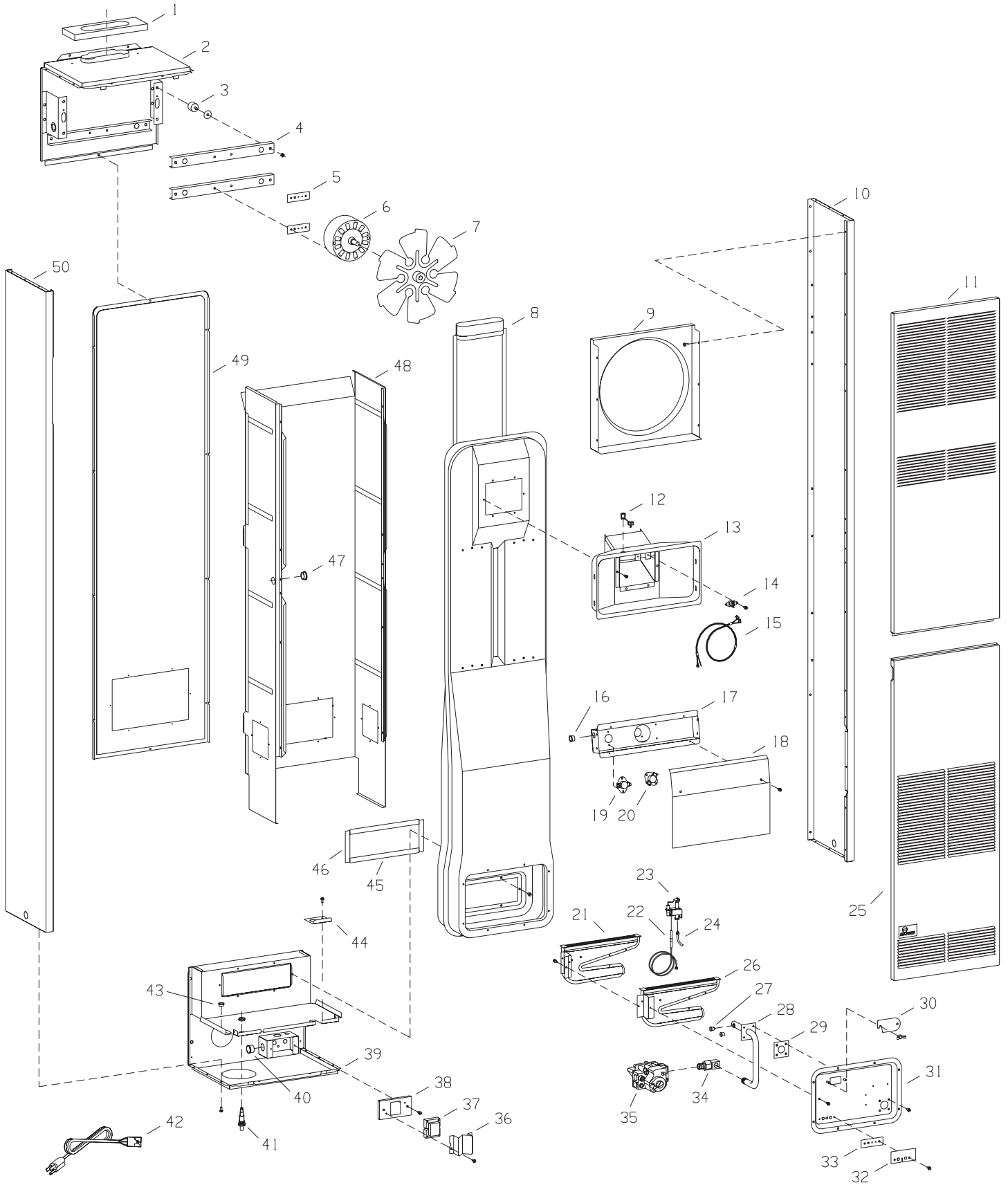

Model No. FAW-55 may be vented as shown. The vent cap must be at least 12 feet (3.7m) above the floor. Clearance to combustible construction is held by the fixed spacers at 1 inch (25mm) with B-1 vent pipe. Installation must conform to local codes.

**4" (102mm) Round** (all parts purchase locally except in item 2)

1. Type B-1 round pipe
2. Part No. DV-648, 4" (102mm) oval-to-round flue adapter kit (see accessories)
3. Single story type B-1 gas vents require a baseplate and one pair of ceiling plate spacers.
4. Multi-story type B-1 gas vents require a baseplate, one pair of ceiling plate spacers at the first floor ceiling and one pair of fire stop spacers at each successive ceiling level.

**4" (102mm) Oval** (all parts purchase locally)

1. Type B-1 oval pipe
2. Single story type B01 gas vents require a baseplate and one pair of ceiling plate spacers.
3. Multi-story type B-1 gas vents require a baseplate, one pair of ceiling plate spacers at the first floor ceiling and one pair of fire stop spacers at each successive ceiling level.

**4" (102mm) Oval In-The-Wall** (wall parts purchase locally)

1. Type B-1 oval pipe
2. Type B01 oval elbows
3. Single story type B-1 gas vents require a baseplate and one pair of ceiling plate spacers.
4. Multi-story type B-1 gas vents require a baseplate, one pair of ceiling plate spacers at the first floor ceiling and one pair of fire stop spacers at each successive ceiling level.

Stud space around gas vents must be free of obstructions and building paper.

Accessories	
Part No.	Description
SOR-1	Register, side outlet, fixed register
SOK-1	Side outlet, 10" (254mm) maximum extension, fixed register
ROK-1	Rear Outlet, 10" (254mm) maximum extension, adjustable register
DV-651	Vent enclosure, 14" (356mm) [for rooms up to 96 1/2" (245cm) in height]
DV-655	Vent enclosure, 24" (610mm) [for rooms up to 106 1/2" (270.5cm) in height]
DV-666	Vent enclosure, 36" (914mm) [for rooms up to 118 1/2" (301cm) in height]
DV-648	4" (102mm) Oval-to-Round flue adapter kit

Use U.L. listed gas vent equipment when installing the FAW-55. For vent pipe running through walls, roof, and within one (1) inch (25mm) of combustible construction, use B01 [one inch (25mm) clearance to combustibles] vent pipe. Type B-2 x 4 or Type B-2 x 6 are to be used in conjunction with a Listed fire stop spacer.

Type BW gas vent pipe is available for single story or multi-story installations, Type BW gas vent pie is to be used with the Listed base plate, ceiling plate spacers and fire stop spacers.

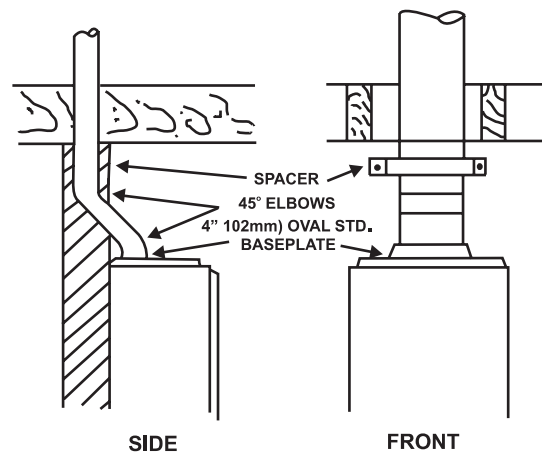
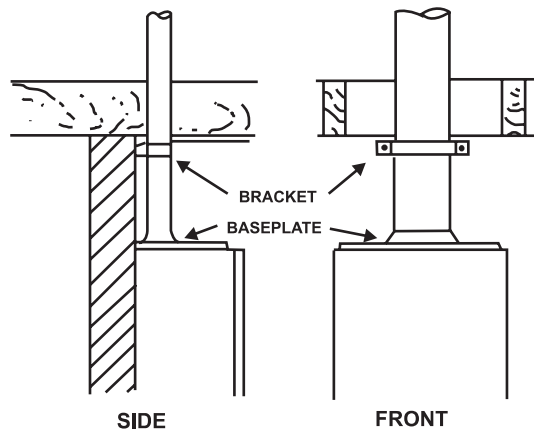
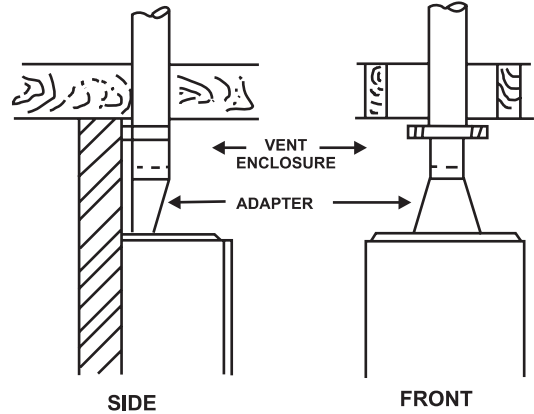

Empire Comfort Systems Inc.  
918 Freeburg Ave. Belleville, IL 62220

If you have a general question about our products, please e-mail us at [info@empirecomfort.com](mailto:info@empirecomfort.com).

If you have a service or repair question, please contact your dealer.